

G 420

HP 14

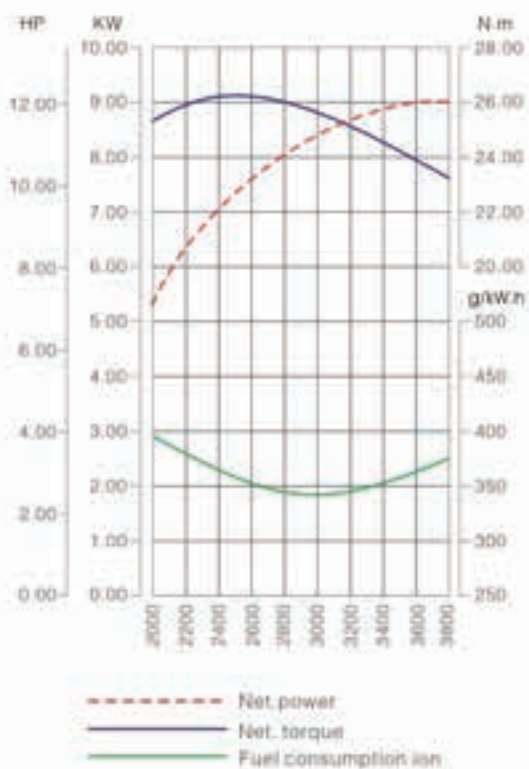

POWERED by
Loncin

MOTORE 4 TEMPI - ENGINE 4 STROKE

Modello Model	Potenza nominale Rated power	Coppia massima Max. torque		Sistema avviamento Starting system	Cilindrata Displacement	Carburante Fuel
type	3600 r.p.m.	Nm	rpm	type	cc	type
Monocilindrico, raffreddamento ad aria, 4 - tempi Single cylinder, forced air cooling, 4 - stroke	9 kW	26,5	2600	manuale - elettrico recoil - electric	420	Benzina Gasoline

Capacità serbatoio Tank capacity	Capacità serbatoio olio Oil tank capacity	Rumorosità Noise	Alésaggio corsa Bore Stroke	Dimensioni Dimensions	Peso a secco Dry weight
lt	lt	≤7m dB (A)	mm	mm	Kg
6,5	1,1	70	90 x 66	405 x 450 x 443	32

VERSIONE / VERSIONS



Albero conico D.23
Cilindric shaft

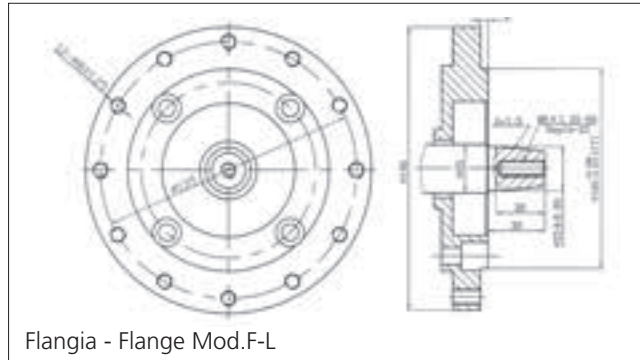

Flangia - Flange Mod.F-L

G 420 F-L

- Albero Conico D.23
- Avviamento Manuale
- Filtro Aria bagno olio



Albero cilindrico D.25,4
Cilindric shaft

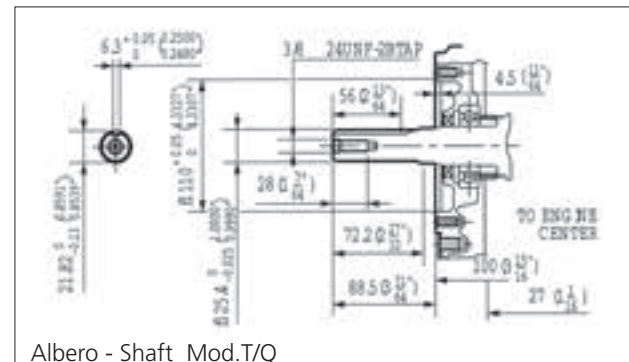

Albero - Shaft Mod.T/Q

G 420 FD-T/Q

- Albero Cilindrico D.25,4
- Avviamento Elettrico
- Filtro Aria a secco



Albero lungo generatore
Generator shaft

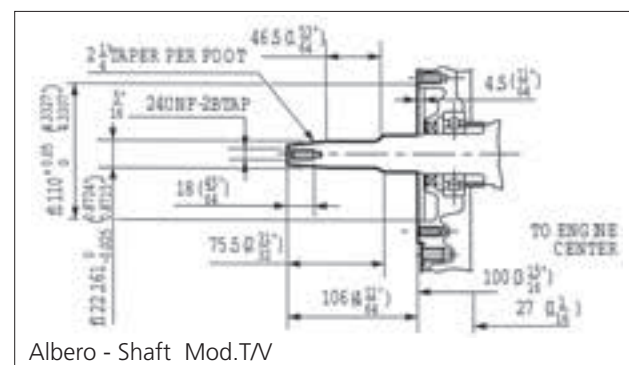

Albero - Shaft Mod.T/V

G 420 FD-T/V

- Albero lungo generatore
- Avviamento Elettrico
- Filtro Aria a secco